

Every once in a while, for reasons that remain entirely obscure, a human being becomes prey to an overwhelmingly forceful urge to count the objects in a really large set. Should you ever succumb to such an urge, the following discussion may be of value to you. A related pathology involves wishing to count the elements of a set whose membership is not so much large as it is confusing to obtain. Again, this discussion should be helpful to you.

Suppose we wish to know in how many ways we can distribute 12 different toys to 10 children (one toy per child). We could just list all the different distributions of the toys, then count them. But since there are $239 \cdot 500 \cdot 800$ different distributions, this would be tedious.

What is the chance that a five card hand contains exactly two pairs; that is, two of one kind, two of another kind, and another card of a third kind. You know that the probability of this equals the number of such hands compared to the number of all five card hands. Again, listing and counting is impractical, because there are $123 \cdot 552$ hands containing exactly two pairs, and $2 \cdot 598 \cdot 960$ five card hands.

It would be nice to have handy formulae by which we could compute such results as mentioned above. Lacking such formulae, some sort of procedure would be OK, if it did not take too long to carry out. So, let us try to discover such formulae or procedures.

■ **Counting by listing**

■ **Tree diagrams**

If there are not too many arrangements to count, listing all the arrangements is practical. Of course, one needs a procedure of carrying out the listing that guarantees no arrangement will be left out of the list and no arrangement will occur twice in the list. A tree diagram is simple to make and intuitively seems to guarantee a complete list. Examples follow.

- Suppose a coin is tossed three times. How many outcomes are there?

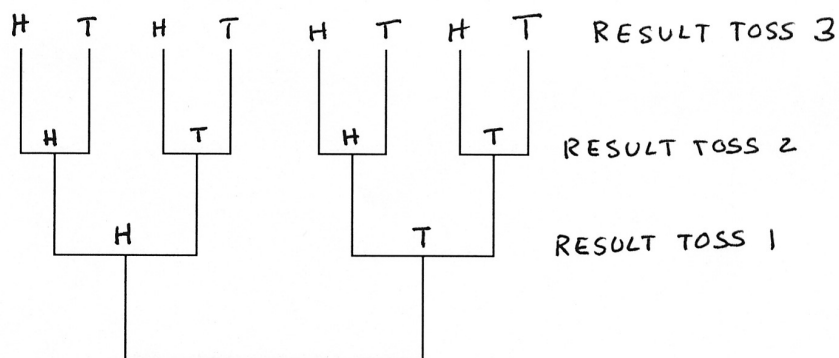

It is clear there are eight outcomes: (HHH), (HHT), (HTH), (HTT), etc

- The USDA defines a complete breakfast as a cup of coffee and a donut. If the menu consists of the following: four flavors of coffee with or without creme and six choices of donuts. How many different complete breakfasts are there?

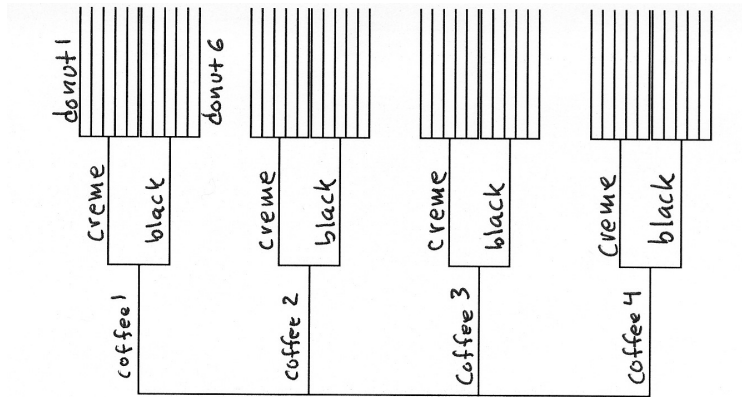

It is clear there are forty-eight outcomes: (coffee1 creme donut1), etc.

Multiplication Principle (Fundamental Theorem of Counting)

If one operation can be performed in n_1 ways and another in n_2 ways, then the two operations can be performed $n_1 n_2$ ways. This is easily extended to any number of operations.

- Applying the multiplication principle to the breakfast example
- How many complete breakfasts (USDA definition) may be ordered from a menu of 4 coffee flavors with or without creme, and 6 kinds of donuts?

Choose a coffee flavor 4 ways
 Choose creme or no creme 2 ways
 Choose donut 6 ways

By the multiplication principle, the total number of complete breakfasts is $4 \cdot 2 \cdot 6 = 48$ breakfasts.

Permutation (ordered arrangement)

A permutation is an arrangement of items in a certain order. Arrangements of the same items, but in different orders are different permutations.

■ Using n out of n items.

- How many 6 letter "words" can be made using the letters A, B, C, D, E, F

[1] if replacement is allowed?

We wish to find all ways to fill in the letters of _ _ _ _ _ _

Choose 1st letter 6 ways
Choose 2nd letter 6 ways
Choose 3rd letter 6 ways
Choose 4th letter 6 ways
Choose 5th letter 6 ways
Choose 6th letter 6 ways

By the multiplication principle, the total number of such words is $6 \cdot 6 \cdot 6 \cdot 6 \cdot 6 \cdot 6 = 6^6$.

[2] if no replacement is allowed?

We wish to find all ways to fill in the letters of

_ _ _ _ _ _

Choose 1st letter 6 ways
Choose 2nd letter 5 ways
Choose 3rd letter 4 ways
Choose 4th letter 3 ways
Choose 5th letter 2 ways
Choose 6th letter 1 ways

By the multiplication principle, the total number of such words is $6 \cdot 5 \cdot 4 \cdot 3 \cdot 2 \cdot 1 = 6!$.

■ Formulae

■ With replacement

Number of n letter words using n letters with replacement = n^n

■ Without replacement

Let the symbol P_n^n represent the number of ordered arrangements, permutations, of n items. Then,

$$P_n^n = n! = n(n-1)(n-2) \cdot \dots \cdot 3 \cdot 2 \cdot 1$$

Using r out of n items.

- How many 4 letter "words" can be made using the letters A, B, C, D, E, F
[1] if replacement is allowed?

We wish to find all ways to fill in the letters of _ _ _ _

- Choose 1st letter 6 ways
- Choose 2nd letter 6 ways
- Choose 3rd letter 6 ways
- Choose 4th letter 6 ways

By the multiplication principle, the total number of such words is $6 \cdot 6 \cdot 6 \cdot 6 = 6^4$.

- [2] if no replacement is allowed?

We wish to find all ways to fill in the letters of

_ _ _ _

- Choose 1st letter 6 ways
- Choose 2nd letter 5 ways
- Choose 3rd letter 4 ways
- Choose 4th letter 3 ways

By the multiplication principle, the total number of such words is $6 \cdot 5 \cdot 4 \cdot 3$.

■ **Formulae**

■ **With replacement**

Number of r letter words using n letters with replacement = n^r .

■ **Without replacement**

$$P_r^n = n(n - 1)(n - 2) \cdot \dots \cdot (n - r + 1)$$

Another expression for this formula is obtained as follows

$$\begin{aligned}P_r^n &= n(n-1)(n-2)\cdots(n-r+1) \\&= n(n-1)(n-2)\cdots(n-r+1) \frac{(n-r)(n-r-1)\cdots 3\cdot 2\cdot 1}{(n-r)(n-r-1)\cdots 3\cdot 2\cdot 1} \\&= \frac{n(n-1)(n-2)\cdots(n-r+1)(n-r)(n-r-1)\cdots 3\cdot 2\cdot 1}{(n-r)(n-r-1)\cdots 3\cdot 2\cdot 1} \\&= \frac{n!}{(n-r)!}\end{aligned}$$

That is,

$$P_r^n = \frac{n!}{(n-r)!} \quad (1)$$

■ **0!**

◆ **Definition**

$$0! = 1$$

Combination (collection)

■ **Permutation**

A permutation is an arrangement. Order matters. In this sense it is like an ordered pair (a_1, a_2) , an ordered triple (a_1, a_2, a_3) or, in general, an ordered n -tuple $(a_1, a_2, a_3, \dots, a_n)$.

■ **Combination**

A combination is a collection. Order does not matter. In this sense it is like a set $\{a_1, a_2, a_3\} = \{a_1, a_3, a_2\}$.

Put another way, consider a class of 13 students. If two students in the class switch seats, it is still the same class. That is a combination. Alternatively, consider a photograph of 13 students on a bench. If two of the students switch places, it is a different photograph. That is a permutation.

Here is another way to think of the difference between a permutation and a combination. Think of choosing a president, vice-president, and a secretary from a pool of 13 students. That is a permutation. For contrast, think of selecting a committee of three from a pool of 13 students. If a certain three students are chosen as members, that is a particular committee. If the same three students are chosen in a different order, it is still that same committee.

■ A formula to compute combinations of r objects from a pool of n objects.

Suppose we form all three member subsets of the four element set $\{a, b, c, d\}$. There are four such sets:

$$\{a, b, c\}, \{a, b, d\}, \{a, c, d\}, \{b, c, d\}$$

Each three element subset gives rise to six different ordered arrangements:

$$\{a, b, c\} \longrightarrow (a, b, c), (a, c, b), (b, a, c), (b, c, a), (c, a, b), (c, b, a)$$

$$\{a, b, d\} \longrightarrow (a, b, d), (a, d, b), (b, a, d), (b, d, a), (d, a, b), (d, b, a)$$

$$\{a, c, d\} \longrightarrow (a, c, d), (a, d, c), (c, a, d), (c, d, a), (d, a, c), (d, c, a)$$

$$\{b, c, d\} \longrightarrow (b, c, d), (b, d, c), (c, b, d), (c, d, b), (d, b, c), (d, c, b)$$

Each 3-combination yields $3!$ (which is 6) permutations of the 3 objects. From a pool of 4 objects, there are four 3-combinations of those objects. Therefore, there are 4 times $3!$ 3-permutations from a pool of 4 objects. In general, the quantity of r -permutations is $r!$ times the number of r -combinations of those n objects.

Let the symbol C_r^n represent the number of r -combinations from a pool of n objects. Then,

$$P_r^n = r! \cdot C_r^n$$

Equivalently,

$$C_r^n = \frac{1}{r!} \cdot P_r^n$$

Noting that $P_r^n = \frac{n!}{(n-r)!}$, we substitute $\frac{n!}{(n-r)!}$ for P_r^n . Then,

$$C_r^n = \frac{1}{r!} \cdot \frac{n!}{(n-r)!}$$

$$C_r^n = \frac{n!}{r!(n-r)!} \quad (2)$$

□

Summary

- A permutation is an arrangement of items in which order matters. The quantity of permutations of n items taken r at a time is called P_r^n and

$$P_r^n = \frac{n!}{(n-r)!}$$

- A combination is an arrangement of items in which order does not matter. The quantity of combinations of n items taken r at a time is called C_r^n and

$$C_r^n = \frac{n!}{r!(n-r)!}$$

Notation

For P_r^n you will often see $P(n, r)$.

For C_r^n you will often see $\binom{n}{r}$, read " n take r " or " n choose r ". The notation $C(n, r)$ is common, too.